

0900

- ▲ **Interior fitments** such as inside liners, pads, partitions, dividers etc., whether tied to Case Design or as singular items. Any shown number of panels is arbitrary and may be increased or decreased as required.
- ▲ **Conditionnement intérieur**, tel que doublures intérieures, rembourrages, casiers, cloisons, etc ... , faisant partie du modèle de caisse ou utilisés comme éléments indépendants. Tout nombre de panneaux indiqué est arbitraire et pourra être augmenté ou diminué selon les besoins.
- ▲ **Inneneinrichtungen** wie Einlagen, Einsätze, Stege, Trennwände, Gefache, Polster und dgl., ob mit der Kiste fest verbunden oder als getrennte Elemente.

Zahlenangaben für Wände sind beliebig und können ggf. höher oder niedriger ausfallen.

- ▲ **Protezioni interne:** Pezzi interni come fodere interne, imbottiture, separatori, divisori ecc., sia come accessori ad un imballaggio, sia come articoli a se stanti. I numeri di pannelli che compaiono nei disegni sono arbitrari e possono essere diminuiti o aumentati secondo le esigenze.
- ▲ **Acondicionadores interiores:** como forros, refuerzos, casilleros, divisiones interiores, tanto si se ajustan a un modelo de caja o como piezas sueltas. El número de piezas de los acondicionadores interiores mostrados es arbitrario y puede aumentarse o disminuirse de acuerdo con las necesidades.

0900

M

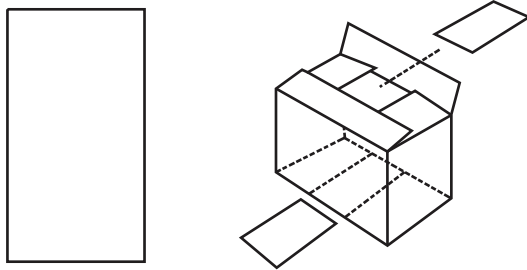

0901

M

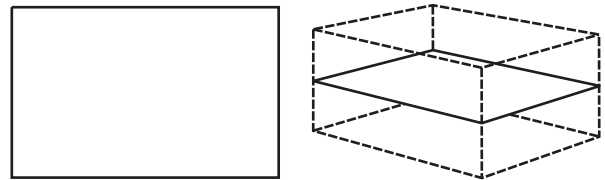

0902

M

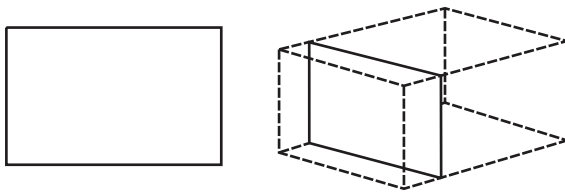

0903

M

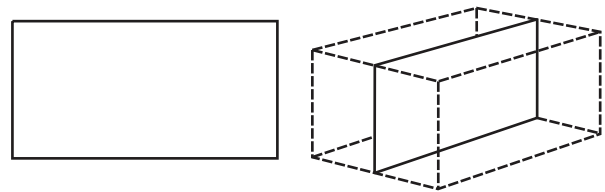

0904

M

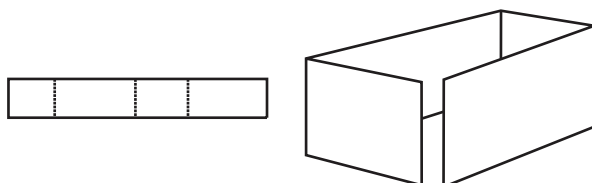

0905

M

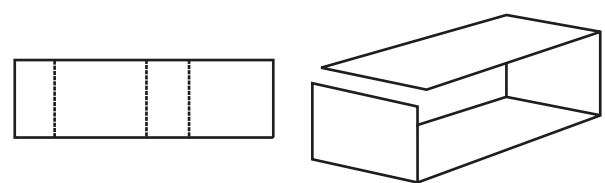

0906

M

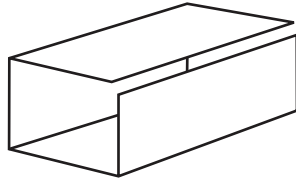
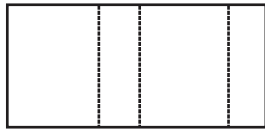

0907

M

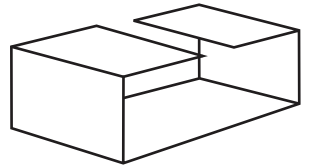

0908

M

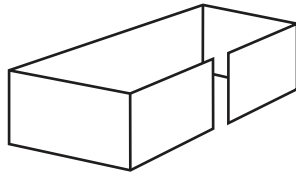

0909

M

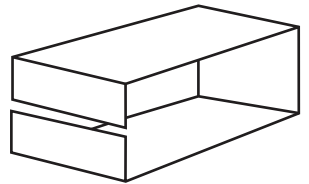
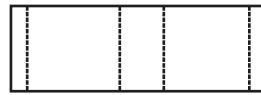

0910

M

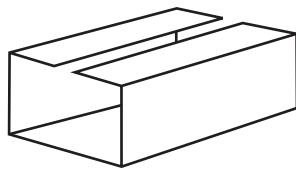
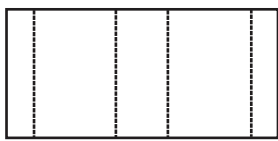

0911

M

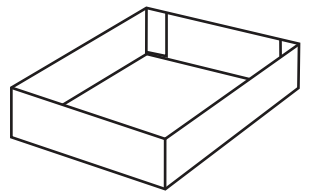
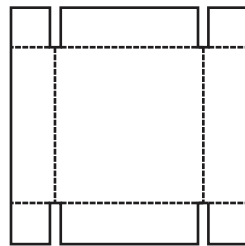

0913

M

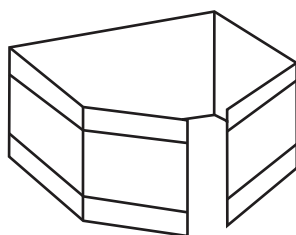
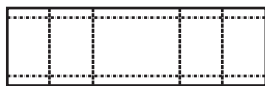

0914

M

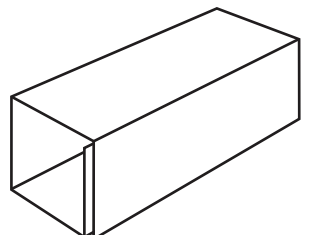

0920

M

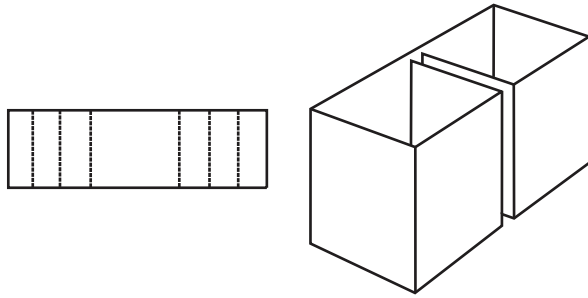

0921

M

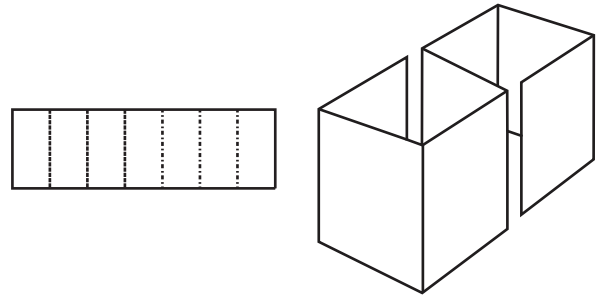

0929

M

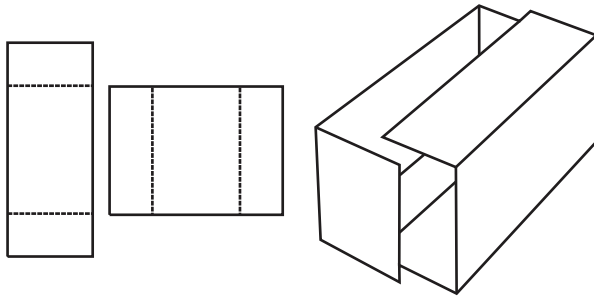

0930

M

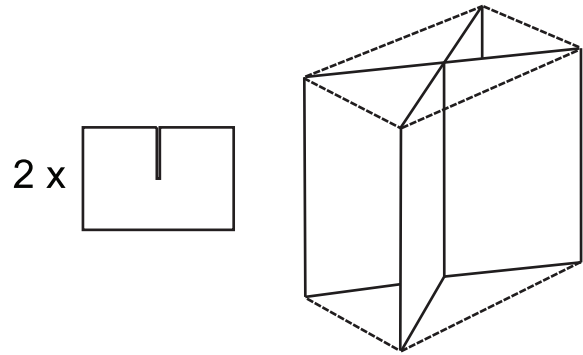

0931

M

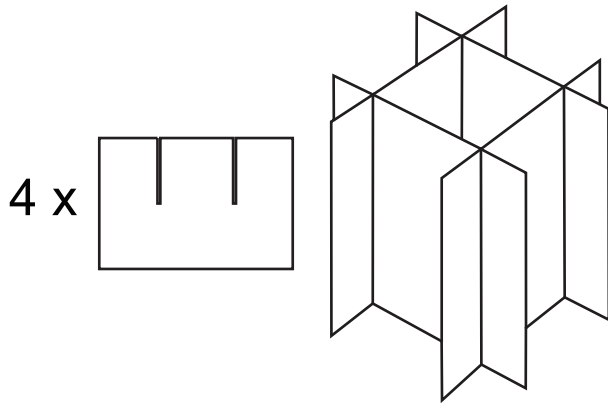

0932

M

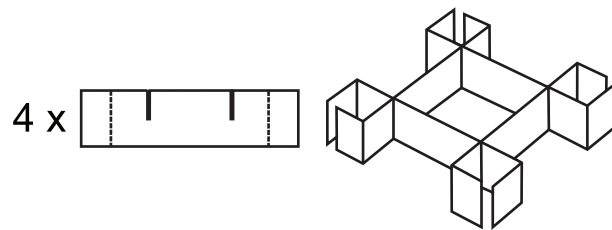

0933

M

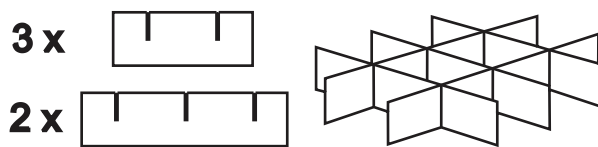

0934

M

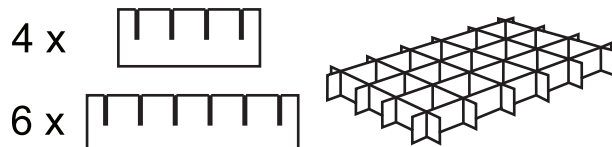

0935

M

2 x

1 x

2 x

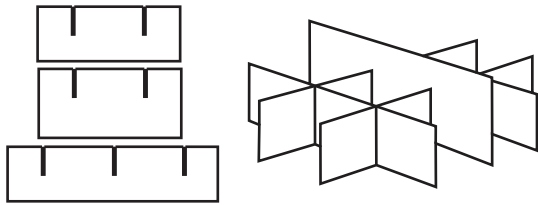

0940

M



0941

M



0942

M

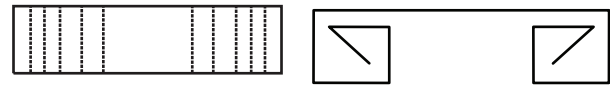

0943

M



0944

M



0945

M



0946

M



0947

M

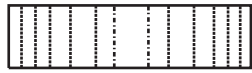

0948

M

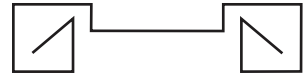

0949

M

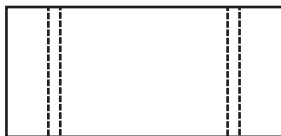

0950

M

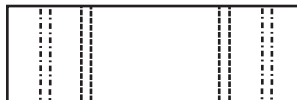

0951

M

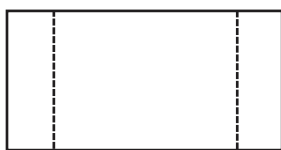

0965

M

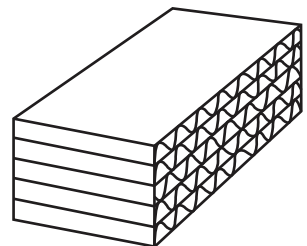

0966

M

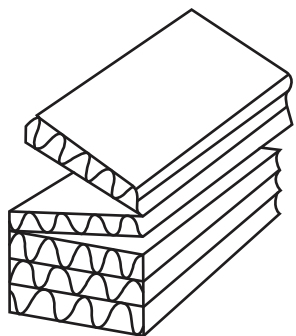

0967

M

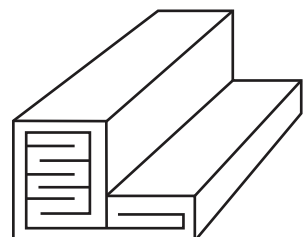
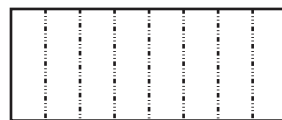

0970

M

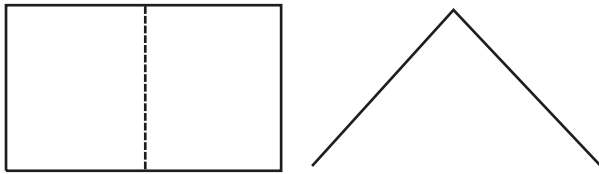

0971

M

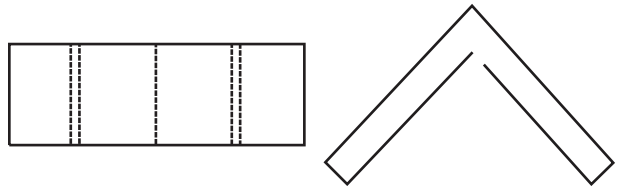

0972

M

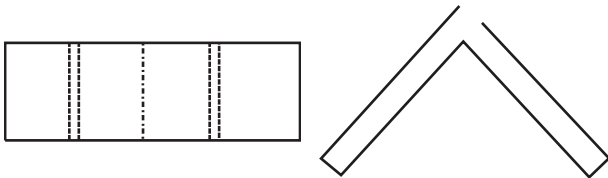

0973

M

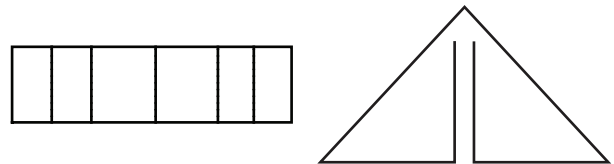

0974

M

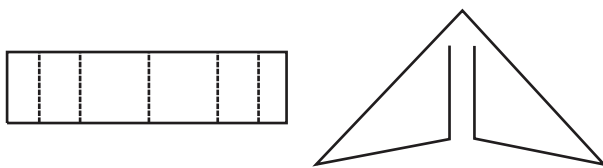

0975

M

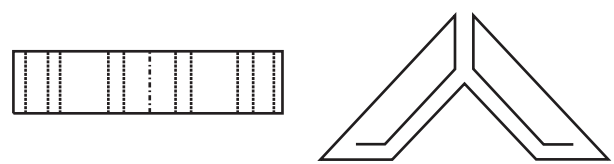

0976

M

